

OPERATING INSTRUCTIONS

Cold cathode gauge head

IKR 020

1. APPLICATION

The IKR 020 gauge head is used together with BALZERS vacuum gauge control units to measure total pressure in the 5×10^{-3} to approx 10^{-10} mbar range. The lower limit of the range is determined both by the sealing material (for gauge head and vacuum connection) and control unit used.

Systems and instruments designed for the IKR 010 gauge heads can be operated without difficulty with the IKR 020. However, the improved features of the IKR 020 such as the extended measuring range cannot be taken advantage of in such cases.

2. ASSEMBLY AND CONNECTION OF THE IKR 020

The IKR 020 can be installed in any desired position when care is taken that no condensates or contamination can collect in the measurement chamber.

The gauge head is connected to the vacuum system by a standard KF or CF flange connection. Before making the connection be sure that the sealing surfaces are smooth and clean, that there are no scratches across the seal, and that the sealing ring itself is clean and not damaged. We recommend using alcohol for cleaning the sealing surfaces and seals. Do not use grease!

For making flange connections refer to operating instructions BA 800 001 BE.

2.1 IKR 020 with DN 40 KF connection

For pressures under 10^{-6} mbar Viton O-ring seals should be used instead of neoprene because of their low outgassing rate.

Metal seals, for example Al or indium, can also be used with KF flange connections (for details refer to "Component Catalog".)

Using reducing centering rings, DN 32 flanges can be connected to DN 40 flanges.

2.2 IKR 020 with DN 35 CF connection

The sealing principle is that two flanges with a copper ring between them are pressed together with such force that the hard knife edges of the flanges cut into the ring from both sides.

The gauge heads can also be mounted using Viton O-rings. This connection may be baked at 120 °C, or briefly at 150 °C.

For installation, the hood containing the magnets is removed:

Turn the cover 90° and pull off.

See Section 8.2.7 for reassembly

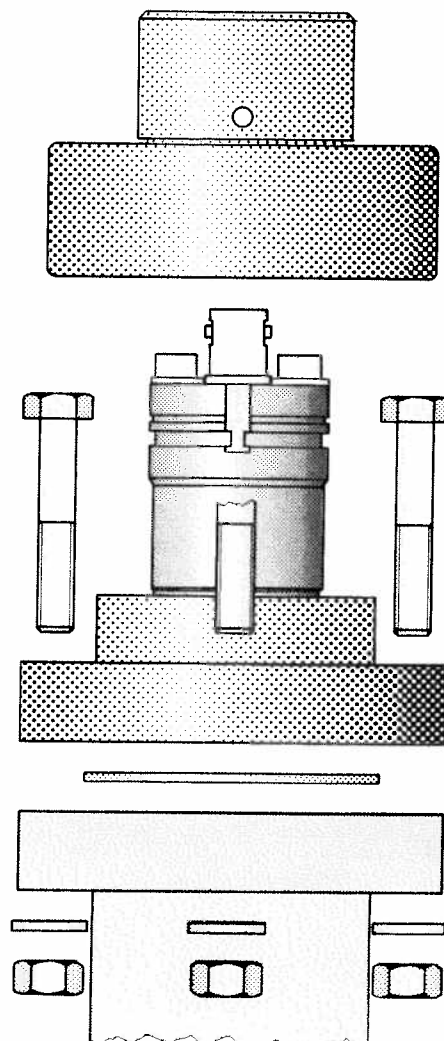

Fig. 1

2.3 Electrical connection

The electrical connection is made using a high voltage coaxial cable which is attached to a current supply and display instrument such as the IKG 010, the IKG 011, the PKG 020, the PKG 100, etc.

Refer to Section 7.3 for cable lengths.

3. MEASURING

Start up and measurement operations are to be undertaken according to the operating instructions of the control unit used.

When measuring very low pressures ($p < 10^{-8}$ mbar) the following must also be taken into consideration:

3.1 Error of measurement

If there is a portion of non-operate current due, for example, to insufficient insulation, the pressure value displayed will be too high.

Check (while instrument is in operation):

- Remove hood with magnets

If the pressure display does not return to zero, there is an insulation malfunction:

Further procedures to find the insulation malfunction:

- Remove cable from the IKR

Display returns to zero – insufficient insulation in the IKR (clean according to Section 8.1.)

Display does not return to zero – malfunction is in the cable (check) or in the supply unit (refer to separate instructions).

3.2 Ignition delay

If the measurement is begun at pressures $< 10^{-8}$ mbar then an ignition delay must be expected. The ignition delay increases with the dropping pressure and can, for example, be 2 – 4 minutes at 5×10^{-10} mbar.

4. ACCURACY OF THE PRESSURE DISPLAY

For a single gauge head, the accuracy or reproducibility of the measured value during a short period is approx. $\pm 5\%$.

The following factors have a great influence on the measurement accuracy:

- Geometry of the electrodes
- Contamination of the electrode surfaces

While the mechanical quality can be accurately checked, deposits of foreign films during the operation cannot be so easily measured. At a constant pressure and increasing contamination, the discharge current diminishes and finally becomes unstable ("jumps" in the pressure display).

The pressure display on the control instrument is based on an average calibration curve between the curve of a brand new gauge head and that of a gauge head with contamination that is just barely still tolerable. Thus the pressure shown by new gauge heads is a little bit too high and that from contaminated gauge heads too low. The possible changes are shown in Fig. 2. (Comparison instrument: Hot cathode ionization gauge).

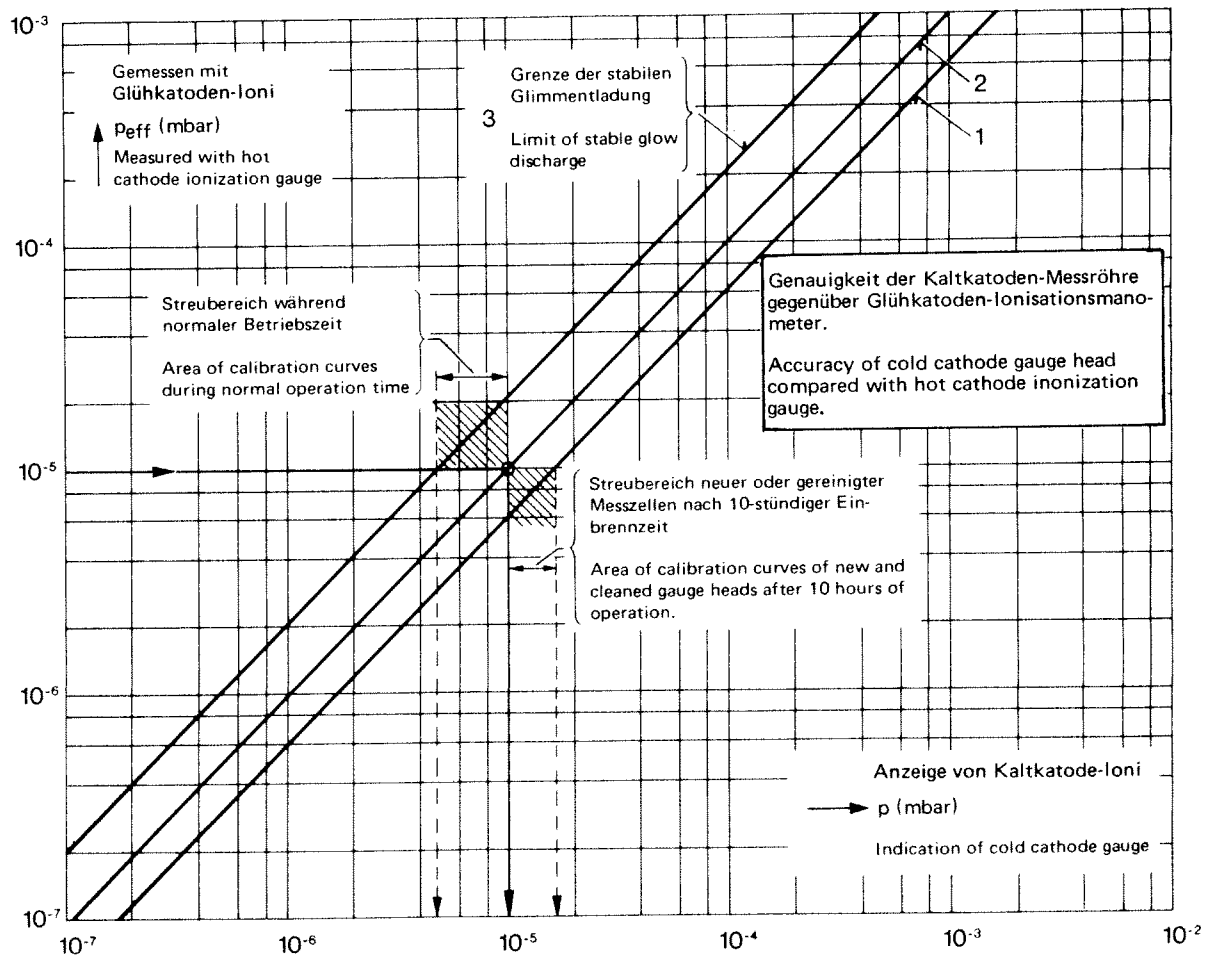

Fig. 2

The values for new or cleaned gauge heads after approx. 10 hours of operation lie within the field between Curves 1 and 2. Experience has shown that gauge heads change the most during this so-called "burn-in" time and then reach a much more stable condition.

During longer operation and increasing contamination the display shifts in the direction of Curve 3. If this boundary is crossed, the discharge becomes unstable. The gauge head must be cleaned.

Note that the curve of the actual measured values need neither run parallel to the boundaries drawn or shift parallel to it. The bordered areas contain the distribution of the values from a large number of gauge heads together, as well as the possible production tolerances and changes in the electronic part.

As shown in the graph, in a bad case the deviation can, for example, be a factor 3 between a new gauge head and a very contaminated one. Normally, especially when the gauge head is not operated to its extremes, the display lies somewhere between +60% and -50% of an absolute average value.

5. MEASURING GASES AND VAPORS

Pressures measured with the cold cathode gauge head are dependent on the type of gas. Usually the control instruments are calibrated for air (N₂).

Finding out the actual pressure:

5.1 Display range 10⁻³ to 10⁻⁵ mbar

The actual values P_{eff} can be determined using the curves in Fig. 3.

Example: Gas = Helium (He)
 Display = 1 × 10⁻⁵ mbar
 actual value P_{eff} = 6 × 10⁻⁵ mbar

5.2 Display range under 10⁻⁵ mbar

The display is linear. For other gases such as air, the pressures can be determined by simple calculation:

$$P_{\text{eff}} = K \times \text{displayed pressure}$$

Example: Gas = hydrogen (H₂)
 Display = 3 × 10⁻⁷ mbar
 actual pressure P_{eff} = 2.4 × 3 × 10⁻⁷ mbar
 = 7.2 × 10⁻⁷ mbar

Type of gas	K
air	1.0
Xe	0.4
Kr	0.5
Ar	0.8
H ₂	2.4
Ne	4.1
He	5.9

Note:

One often has to deal with mixtures of gases and vapors. In such cases the composition can only be determined with a partial pressure measuring instrument.

The calculation factors given are average values. Please note Section 4 "Accuracy of the pressure display".

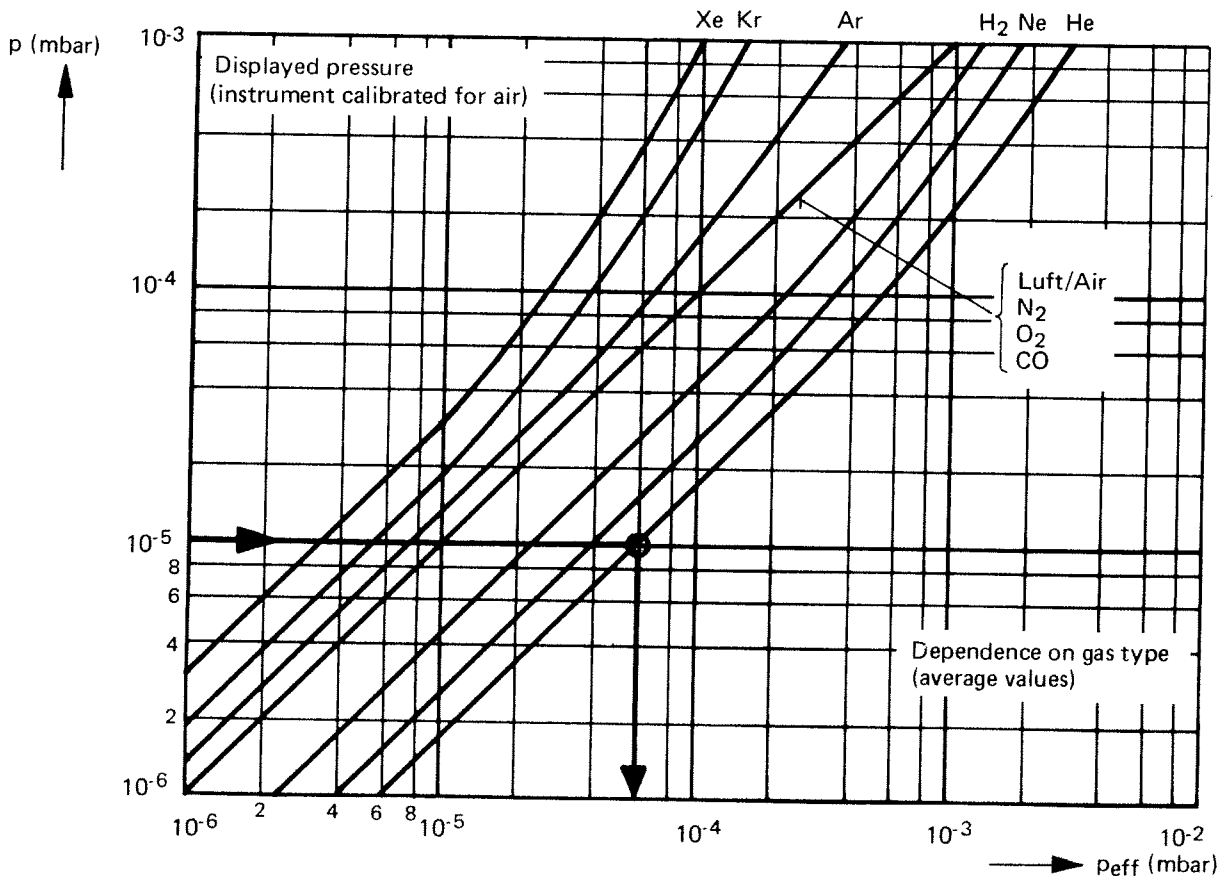

Fig. 3

6. TECHNICAL DATA

Order Nr.	Connection DN	Measuring range from 10^{-3} mbar to	Temperature resistance to $^{\circ}\text{C}$	Radiation resistance rad	Anode insert seal
BG G12 510	40 KF	10-10 ¹)	150	10 ⁴	Viton
BG G12 515	40 KF				Copper 2)
BG G12 511	35 CF				
BG G12 516	40 KF			10 ⁹	
BG G12 513	35 CF				

Operating voltage: 3.3 kV
 Max. glow discharge current 0.7 mA
 Weight, without cable 0.5 kg

- 1) Lower limits determined by the control unit used
- 2) Copper seal (Helicoflex/made by Cefilac) can withstand a minimum of 10 bakeout cycles from 25 to 250 $^{\circ}\text{C}$ at a temperature rise of max. 5 $^{\circ}\text{C}/\text{min}$.

Materials coming into contact with the substrate in the vacuum system:

Housing: 1.4016 / 1.4034 / 1.4104 / 1.4301
 HV feedthrough: Ceramic (Al_2O_3)
 Seal: Viton or copper
 Anode: Molybdenum / Chopper
 Flange 40 KF: } 1.4036
 35 CF: }

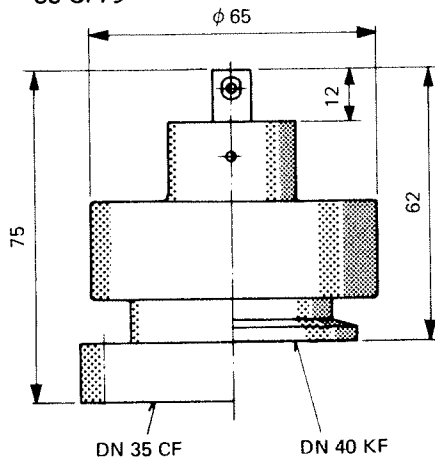

Fig. 4 Scale drawing

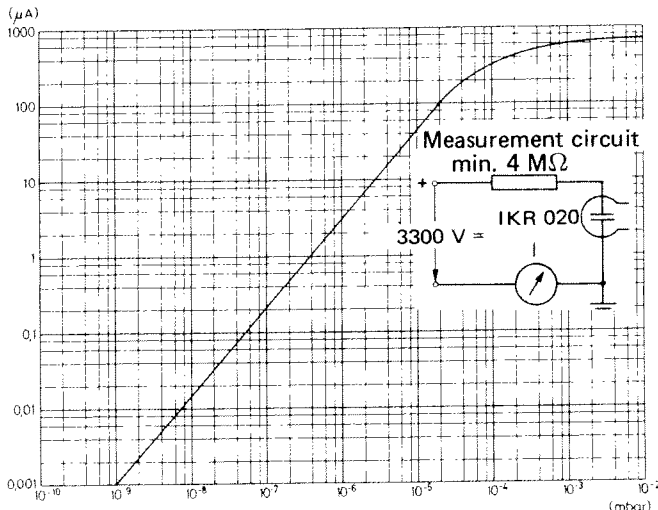

Fig. 5 IKR 020 characteristic curve

7. PRINCIPLE OF OPERATION

7.1 Method of measurement (gas ionization with cold cathode)

The current flowing in an autonomous gas discharge in the high vacuum range depends on the applied voltage, on the gas composition and on the pressure. A magnetic field penetrating the discharge space causes the electrons to move from the cathode to the anode on a spiral trajectory. Thus, even at very low gas density, a sufficient number of ionizing impacts occur. The discharge current is a measure of the pressure for a certain gas composition if the anode voltage and the magnetic field remain constant.

7.2 Description

The reliable IKR 020 gauge head is made chiefly of metal, the measurement chamber as well as the connection flange of stainless steel. The magnetic field is produced outside the measurement chamber by a permanent magnet.

It is supplied with a stabilized direct voltage of 3.3 kV. The current is limited by the measurement circuitry to approx. 700 μA according to Fig. 5. The special design avoids glow discharge breakdown throughout the whole measuring range. The measurement current is stable, virtually inertia free and reproducible within narrow limits. Short operating times at high pressures or inrushes of air do not affect the function of the IKR 020. The gauge head can be disassembled for cleaning purposes. Calibration is restored after short operation.

Depending on the intended bakeout temperature, the ceramic anode voltage feedthrough is either Viton or metal sealed.

Older versions of this gauge head use gold seals. If gold seals are not desired, it is possible to convert this version of the gauge head using a special conversion kit. Refer to Section 10. "Accessories".

7.3 Measurement cable

A coaxial cable is used for connection to the control instrument. It is equipped with bayonet joints at both ends. Standard cable lengths are 2, 3 and 6 meters. Longer cables are available on request. Refer to Section 9 for individual parts or assembly instructions for making measurement cables.

Normally the length of the cable does not influence the measurement.

Note:

If, however, pressure measurements in the range $< 10^{-8}$ mbar are planned with cables > 25 m, we recommend using a triaxial

measurement cable. With it measurement errors due to cable insulation leak currents are eliminated.

Cable lengths up to 500 m are possible with an appropriate adjustment of the control instrument.

8. MAINTENANCE

Contamination of the gauge head, and thus the accuracy of measurement, is greatly dependent on:

- contaminants in the environment such as dust, oil vapors, etc.
- working pressure
- length of operation

Thus the time period until a cleaning becomes necessary can be a matter of days or a matter of months. Instability of the discharge current becomes noticeable through "jumps" in the pressure display. A more experienced eye can also judge the degree of contamination in the measurement chamber.

8.1 Disassembly and cleaning of the gauge head (Fig. 6)

- 8.1.1. Disconnect cable to gauge head and remove the gauge head from the vacuum system.
2. Remove the cover together with the magnets (3) by turning 90° until the fixation knob rises slightly.
3. Remove the tension ring (7) and the pole insert (6)
4. Remove the four screws (11) using the SW3 hex socket head wrench.
5. Remove the pressure piece (5), the entire anode (2), the spacing and support rings (9, 16, 10) and seal (13).
6. Cleaning: Polish the inside of the measurement chamber (1), the sealing surfaces of the measurement chamber, and the surfaces of the pole insert (6) turned towards the measurement chamber, with a fine emery cloth (grain size 400) or a household cleaning agent (take powdered cleaning agent and make into a paste using hot water, apply with a brush or cloth and rub the parts until they are clean).

The sealing surfaces may only be rubbed concentrically!

7. The anode pin is to be cleaned in the same way using a paste made from a household cleaning agent, or a fine emery cloth.

Don't bend the anode, don't treat the ceramic part!

If deposits cannot be removed, the complete anode is to be replaced.

8. Replacement of the ignition aid (8) after each cleaning is advantageous.
9. Rinse all parts that have been cleaned in alcohol and rub dry with a clean cloth or dry using hot air (hot air blower or oven at 40 °C).

8.2 Reassembly (Fig. 6)

- 8.2.1. Place the pole insert (6) with tension ring (7) into the measurement chamber and cover with plastic cover (18) to protect sealing surfaces.
2. Place seal (10) with supporting ring (13) in the measurement chamber
3. Push ignition aid (8) onto the anode. There should

be 1 – 1.5 mm between the ceramic part and the ignition aid. (also refer to Fig. 7)

- 8.2.4. Place the complete anode in the measurement chamber. Lay disk (16) on the ceramic part, and the spacing ring (9) in the measurement chamber.
5. Place the pressure piece (5) with receptacle (14) screwed on perpendicularly on the anode.
6. To prevent leaks, the following work must be carried out with particular care:
Lubricate the four screws (11) with temperature resistant thread lubricant (450 g tube, Order Nr. B 0480 126). Put disks (12) in place and screw in screws by hand. Then tighten the screws evenly on the diagonal in 0.5 Nm (5 cmkg) stages to 3 Nm (30 cmkg) using the hexagonal socket head wrench.
7. Mounting the cover (3, 4): Align the fixation knob on the cover with the grooves in the measurement chamber (see Fig. 1) and place the cover on the measurement chamber. Push the fixation knob (4) down and turn by 90°.

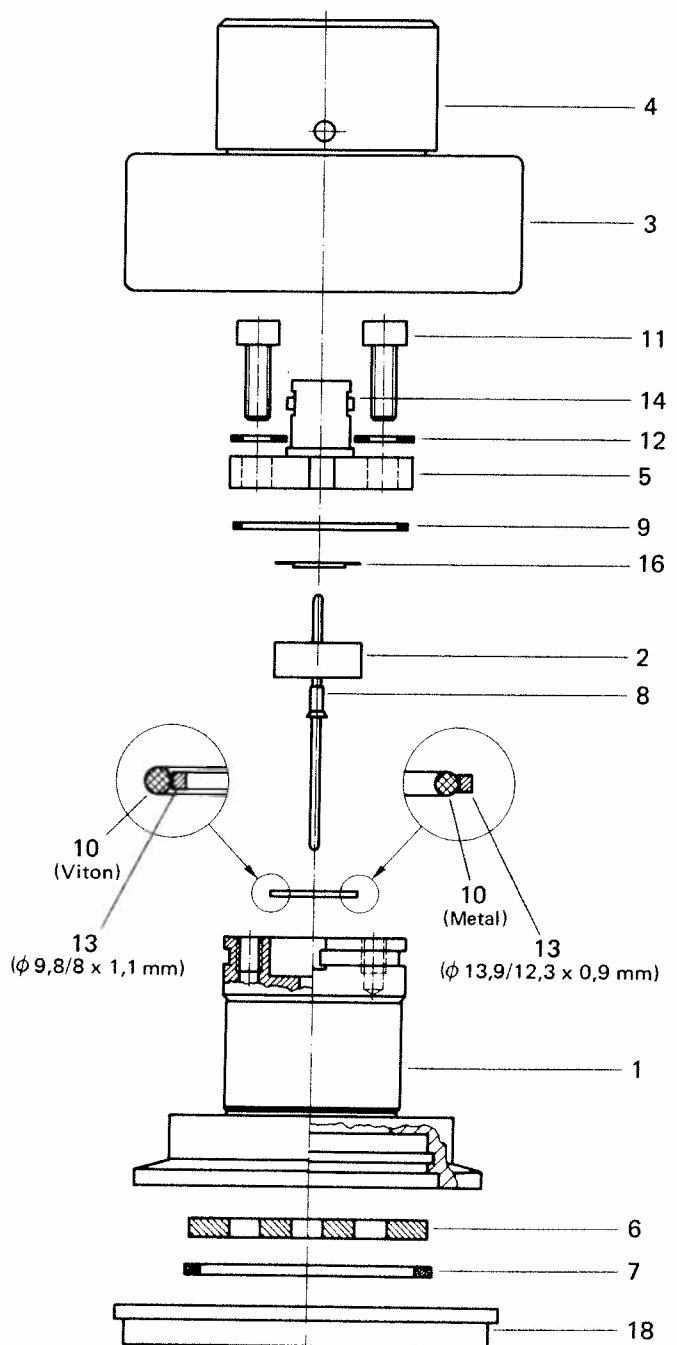

Fig. 6

8.3 Testing the gauge head after cleaning

- 8.3.1 Make a visual check that the anode pin is lying centrally to the pole insert. If this is not the case (anode pin bent) the anode must be replaced.
- 2 If arcs occur inside the gauge head between the measurement chamber and the ignition aid (3300 V), the ring gap must be enlarged somewhat with a pair of tweezers (remove cable).
- 3 Leak test: Permissible leak rate is $\leq 10^{-9}$ mbar l/s, with Viton O-ring $< 10^{-8}$ mbar l/s
4. Compare with ionization gauge head as per curve sheet Fig. 5.

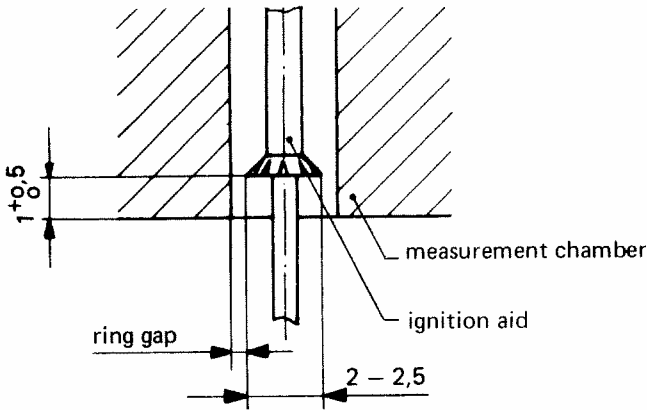

Fig. 7

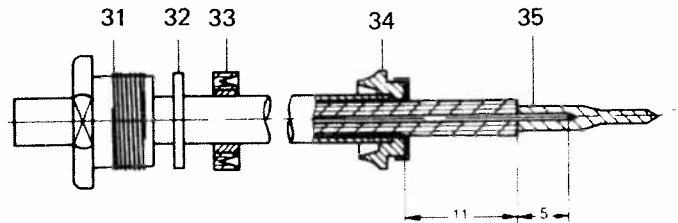

Fig. 9

- 9.4 Check the protruding length of the dielectric. Apply tin lightly to the inner conductor. Cooling the dielectric with a suitable metal template prevents deformation of the material.
- 9.5 Carefully solder the inner conductor contact (35) to the cable inner conductor. The space between conductor and contact must be entirely filled with tin. Furthermore, the contact must rest flush against the front face of the dielectric.
Carefully remove excess quantities of tin from the inner conductor contact.

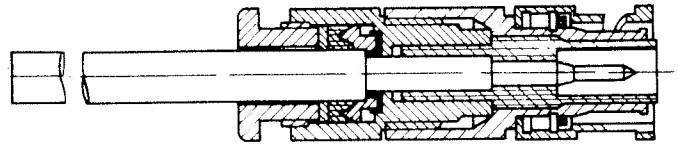

Fig. 10

- 9.6 Introduce the cable end into the plug body while turning it slightly in both directions. The tip of the inner conductor contact must be brought in the position relative to the plug front as shown in Fig. 10. Push the seal and the washer into the plug and screw the nipple to the housing.

9. MAKING A GAUGE HEAD CABLE

When making a cable of special length or for repair, proceed as follows:

- 9.1. Cut off cable sleeve and cable insulation to the dimensions given in Fig. 8.

The conductors must not be damaged. Undo the plaited screening and bend it towards the inner conductor.



Fig. 8

- 9.2 Push nipple (31), washer (32), seal (33) and fixing bushing (34) on onto the cable as per Fig. 9. The inner rim of bushing (34) should lie against the cut end of the cable sleeve.
- 3 Bend the screening outwards and around the fixing bushing (34). Cut it off neatly as shown in Fig. 9.

10. ACCESSORIES

Coaxial cable, complete with plug connector, as the connection between the gauge head and the control unit:

2 m long, order nr.	BG 520 401 -T
3 m long, order nr.	BG 520 247 -T
6 m long, order nr.	BG 520 601 -T

IKR 020's with the order numbers BG G12 500 to BG G12 507 are models in which the anode has a gold seal. The following conversion kits allow these anode to be converted to the use of a Viton or copper/Helicoflex (spring supported copper seal) seal.

Conversion:

from gold to Viton 1)	BN 845 500 -T
from gold to copper/Helicoflex 2)	BN 845 504 -T

- 1) Conversion instructions BG 800 156 BN
- 2) Conversion instructions BG 800 159 BN

Refer to Balzers "Component Catalog" for control units, assembly and sealing materials.

The various sealing possibilities as well as the sealing materials can be also taken from the operating instructions on the production of flange connections BA 800 001 BE.

11. SPARE PARTS

Order spare parts according to the enclosed spare parts list.

When ordering please state type and serial number of the instrument as shown on the nameplate.

Ordering example:

1 anode comp., order nr. BG 510 959 -X, according to spare parts list BG 800 105 E, Item 2.

	Description Teil	Item Pos.	Order No. Bestell-Nr.	S	Reference Bemerkungen
		1			
1	Anode compl. / Anode kpl.	2	BG 510 959 -X		
1	Cover with permanent magnet / Haube mit Magnet	3	BG 510 997 -X		
		4			
		5			
1	Pole insert / Poleinsatz	6	BG 510 964		
1	Save guard / Sprengring	7	BG 510 965		
1	Igniter / Zündhilfe	8	BG 510 968		
1	Disc / Scheibe	9	BG 510 988		
1	Ring, ϕ 28/25 x 1,05 mm	10a	BG 510 992		Metall
1	Ring, ϕ 28/25 x 1,3 mm	10b	BG 510 989		Viton
1	Centerring / Zentrierring, ϕ 13,9/12,3 x 0,9 mm	11a	BG 510 993		Metall
1	Supportring / Stützring, ϕ 9,8/8 x 1,1 mm	11b	BG 510 991		Viton
		12			
4	Screw / Schraube, M4 x 12 mm,	13	N 3059 255 X		
4	Spring disc / Spannscheibe, ϕ 4,3 / 9 x 1,1 mm	14	N 3543 146 Y		
1	Seal / Dichtung HN 100, ϕ 9 / 12,2 x 1,6 mm	15a	B 0140 233		Metall
1	O-Ring, Viton, ϕ 10,82 x 1,78 mm	15b	B 4070 164 PV		Viton
1	Socket / Chassisbuchse	16a	B 4728 459 B9		
1	Socket, rays resistant / Chassisbuchse, strahlungsbeständig	16b	B 4728 458 B9		
1	Cover / Deckel	17	B 4728 907 BA		
	Cover / Schutzdeckel	18a	B 8080 258		DN 40 KF
	Protectiv flange / Transportflansch	18b	BP 414 266		DN 35 CF
2	Plug / Kabelstecker 11 H4 - 50 - 3 - 1	19a	B 4728 401 B9		standard
	Plug, rays resistant / Kabelstecker, strahlungsbe., 10^9 rad	19b	B 4728 408 B9		
	Coaxial cable reys resistant, 10^8 rad / Koax-Kabel, strahlungsbeständig, 10^8 rad	20	B 4582 232 SE		Lenght as required / Länge nach Bedarf
1	Guard ring / Sicherungsring, J37 x 1,5 mm	21	N 3828 624 SV		

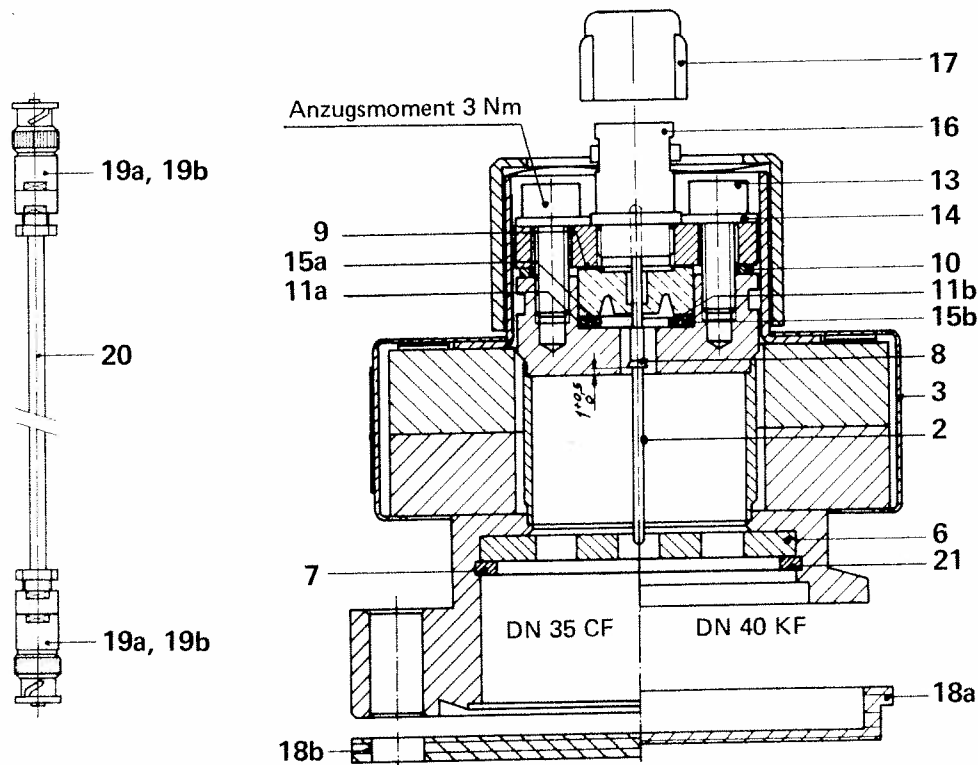

Spare Parts for / Ersatzteile zu

IKR 020

BG G12 510
BG G12 511

ab Fabr. Nr.:
from Serial No.:
à partir du no. de fabr.:

4500

BALZERS

BG 800 105 E/2