

OPERATING INSTRUCTIONS

Penning module

PE 420

TABLE OF CONTENTS

	Page:
1. INTRODUCTION	1
2. FEATURES	2
3. SPECIFICATION	2
4. DESCRIPTION	3
5. CONFIGURATION	3
6. INSTALLATION	4
7. PROGRAMMING	4
8. MAINTENANCE	6
9. DETAILED DESCRIPTION	6
9.1 Principle of measurement for the IKR	6
9.2 A/D converter	7
10. ACCESSORIES	7
APPENDIX: Layout	8

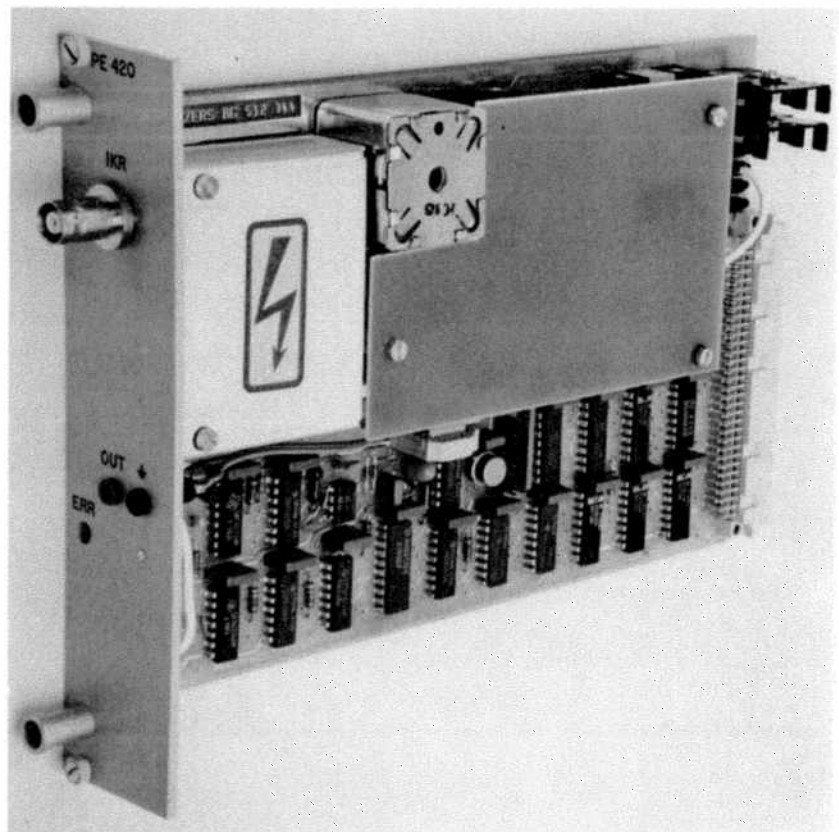

1. INTRODUCTION

The PE 420 vacuum measurement module is used for total pressure measurement in the pressure range from $5e^{-3}$ to $4e^{-10}$ (5×10^{-3} to 4×10^{-10}) by the cold cathode gas ionization method.

2. FEATURES

- 12 (11) bit resolution
- 3 control bits
- analog control output
- control LED

3. SPECIFICATION

General

Designation	PE 420
Parts list/Order Nr.	BG 512 744 -T
Diagram	BG 541 177 -S
Drawing Nr.	BG 512 727 -Z BG 512 739 -Z BG 512 741 -Z
Board format:	DIN 4-HE * 220 mm (SC 420 format)
Space requirements	8TE (2 slots)

Power consumption	+5 V \pm 5% 450 mA
	+24 V \pm 5% 100 mA
	-24 V \pm 5% 50 mA

Bus interface	as for BS 420
Bus load	AC 1.3 (1 = 9.35 pF) DC 0.5 (1 = 0.103 mA)

Penning data

Measurement range (N2)	5.0e-3 ... 4.0e-10
Absolute error of measurement	Factor 2
Reproducibility	\pm 5%
Gas type dependency	(see calibration curve)
Digital data	11 bit binary
Control bit	Out-of-range (measurement range) HV error (high voltage) on/off

IKR connector	BNC / socket 22 H4-50-0-1
---------------	---------------------------

Control output OUT	0 – 10 V, Ri approx. 100 Ohm 2 mm socket
	0.0V 4.0e-10mbar 6.0V 3.0e-6mbar
	1.0V 1.5e-9mbar 7.0V 1.2e-5mbar
	2.0V 7.0e-9mbar 8.0V 4.0e-5mbar
	3.0V 3.0e-8mbar 9.0V 3.0e-4mbar
	4.0V 1.5e-7mbar 10 V 5.0e-3mbar
	5.0V 6.0e-7mbar

4. DESCRIPTION

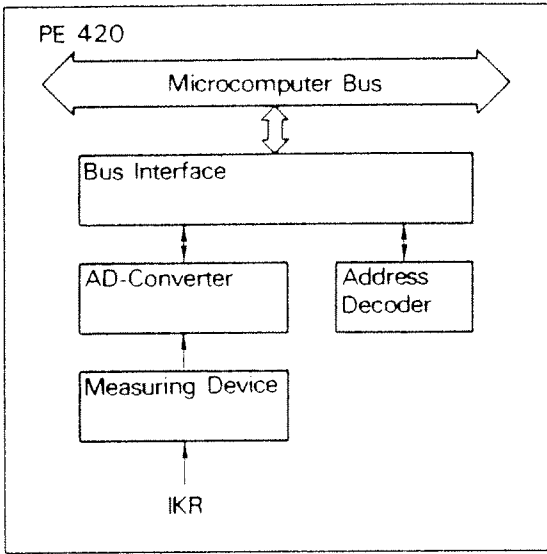

The board contains the IKR MEASURED DATA PROCESSING, AMPLIFIER, ANALOG/DIGITAL CONVERTER and the BUS INTERFACE.

5. CONFIGURATION

The position of the address jumpers and the coding switches can be taken from the lay-out plan (Appendix).

Octal

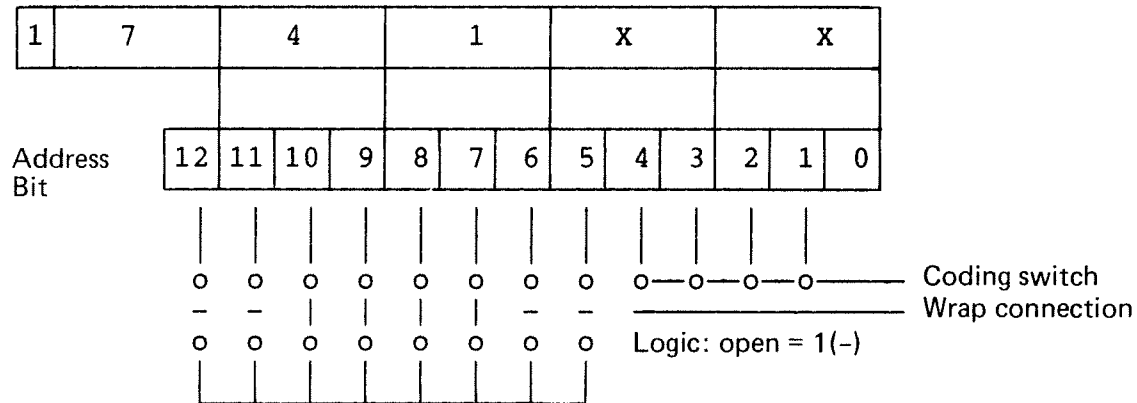

The bus address is set at the factory to %O 1741xx. This can be changed over the wrap connection if necessary.

Using the hexadecimal coding switch, the address is set in continuous sequence from O 174100 to O 174136 i.e. the first board to 0, the second to 1, etc. In this way 16 boards and thus 16 gauge heads can be addressed without changing the base address.

Each board has one address.

There is thus one data word per board (both read and write) available to the computer.

6. INSTALLATION

— The unit must be turned off before any manipulation is undertaken on the module or its connector.
Please read Section 6.3 "Installing the modules" in the SC 420 operating instructions.

7. PROGRAMMING

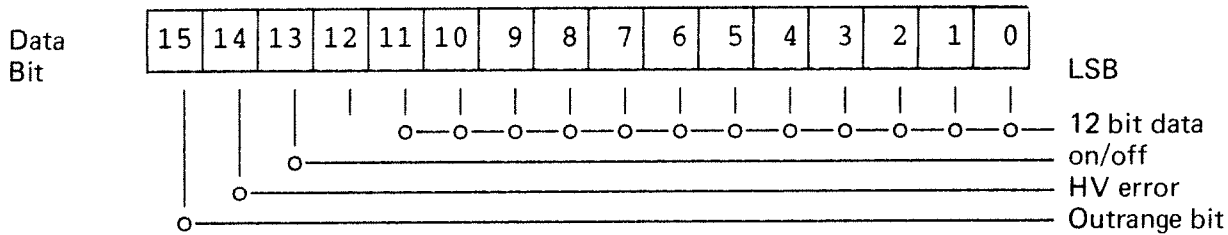

Bit 15 = Penning measured data out of range (read only)
Bit 14 = High voltage error (read only)
Bit 13 = switch on/off (read/write)
Bit 1 – 11 = measured data (read only)
Bit 0.12 not used (Bit is a toggle bit for the counting A/D converter)

The board can only be read and turned on.

The 16 bit word contains the status and the measured data for one gauge head.

EXAMPLE in MicroPowerPascal (DEC)

```
[SYSTEM(MICROPOWER)] PROGRAM read_pe_value;
(* -----
C
C COPYRIGHT (c) 1985 BY BALZERS AG,
C FL-9496 BALZERS, LIECHTENSTEIN
C ALL RIGHTS RESERVED.
C
C THIS SOFTWARE IS FURNISHED UNDER A LICENSE AND MAY BE USED AND COPIED
C ONLY IN ACCORDANCE WITH THE TERMS OF SUCH LICENSE AND WITH THE
C INCLUSION OF THE ABOVE COPYRIGHT NOTICE. THIS SOFTWARE OR ANY OTHER
C COPIES THEREOF MAY NOT BE PROVIDED OR OTHERWISE MADE AVAILABLE TO ANY
C OTHER PERSON. NO TITLE TO AND OWNERSHIP OF THE SOFTWARE IS HEREBY
C TRANSFERRED.
C
C File Name : EXAMPL.PAS
C Creation : 04-SEP-85
C Author : /ESS
C Version : V01.00
C
C
*)
```

```

CONST
  penning_adresse = %O'174100';    (* Penning Hardware Address *)

TYPE
  IKR_020 = [VOLATILE] PACKED RECORD
    data:    [POS(1),BIT(11),READONLY] 0..2047;
    on:      [POS(13)] BOOLEAN;
    hv_on:   [POS(14),READONLY] BOOLEAN;
    outrange: [POS(15),READONLY] BOOLEAN;
  END;

VAR
  penning : [AT (penning_adresse)] IKR_020;

BEGIN      (* PROGRAM read_pe_value *)
  (* ----- *)
  WRITE ("Penning: ")
  WITH penning DO BEGIN
    on: = TRUE;          (*SWITCH ON*)
    IF hv_on THEN
      IF outrange THEN WRITE ("Outrange")
    ELSE BEGIN
      IF data >= 1880 THEN
        WRITE (EXP (2.30259 * (data / 2047 * 15 - 17.3)))
      ELSE
        WRITE (EXP (2.30259 * (data / 2047 * 6.4 - 9.4)));
    END;
    ELSE WRITE ("Error");
  END;
END.      (* PROGRAM read_pe_value *)

```

8. MAINTENANCE

The Penning modules are calibrated at the factory and need no maintenance.

9. DETAIL DESCRIPTION

9.1 Principle of measurement for the IKR

The IKR measurement is based on the principle of high voltage cold cathode gas ionization (3.3 kV).

The current in a glow discharge sustained in a measurement chamber under low pressure is dependent on the type of gas (refer to the operating instructions for the gauge head), the pressure and the glow discharge voltage.

This electronic measurement and control device is designed so that the pressure dependent glow discharge current is measured in the lower pressure range ($p < 3e-5$ mbar) by a high sensitivity logarithmic amplifier at a constant high voltage.

In the upper pressure range ($p > 3e-5$ mbar) the gauge head is operated on a limited glow discharge current. The control voltage necessary for this is a function of the pressure. It is corrected in a diode network before the data is processed. These two pressure-dependent signal voltages (from the logarithmic amplifier and the resistor network) are added in a summing amplifier and form the pressure proportional output voltage.

Particularly in the lower pressure range ($3e-5 \dots 4e-10$ mbar) the output voltage, as a function of the pressure, is very logarithmic and extends across 7 decades. This pressure dependent output voltage is further processed in the digital part. It is also available at the control output.

The high voltage for the gauge head (3.3 kV) is produced and rectified in a push-pull high voltage converter with following voltage doubling circuit.

9.2 Analog/digital converter

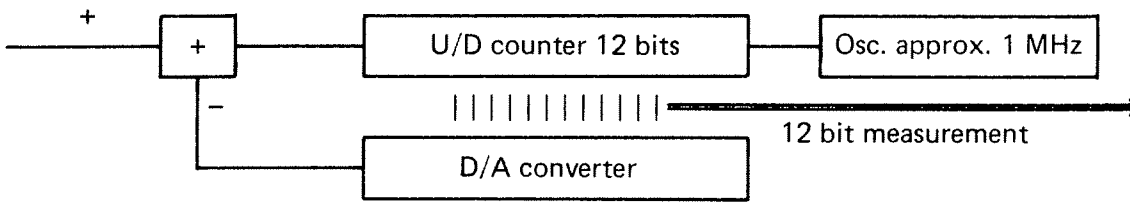

The A/D converter consists of a 12 bit bidirectional counter, a 12 bit D/A converter and a clock generator.

The input voltage ($U_e = 0 - 10 \text{ V}$) is compared with the D/A converter's compensation voltage. The D/A converter used in this circuit has a current output and produces a compensation current of between 0 and 4 mA over a 2K5 resistor.

If the voltage drop at 2K5 is lower than the input voltage, the counter increments. This increases the current i.e. the voltage drop until it equals the input voltage. When the difference is $> 1/2 \text{ LSB}$, the comparator switches over at every clock beat. (The last bit jumps back and forth constantly (toggle bit)). The 12 bit counter value corresponds to the binary input voltage value ($10 \text{ V} = 7777 \text{ octal}$).

If the input voltage changes, the counter and thus the compensation voltage also change at a speed of approx. $2.5 \text{ mV}/\mu\text{s}$ at a frequency of 1 MHz (tracking A/D converter).

The clock generator is stopped when the digital values are being read.

This type of A/D converter allows fast data access (necessary for the control functions) and guarantees that RF interference has little effect on the accuracy of measurement.

10. ACCESSORIES

Please refer to the Balzers catalog "Vacuum Components"

APPENDIX A: PE 420 PENNING MODULE BG 512 727 -Z
 BG 512 739 -Z
 BG 512 741 -Z

