

## OPERATING INSTRUCTIONS

### Pirani module

PI 420

#### TABLE OF CONTENTS

	Page
1. INTRODUCTION	1
2. FEATURES	2
3. SPECIFICATION	2
4. DESCRIPTION	3
5. CONFIGURATION	3
6. INSTALLATION	4
7. PROGRAMMING	4
8. MAINTENANCE	6
9. DETAILED DESCRIPTION	6
9.1 Control bridge circuit	6
9.2 A/D converter	7
10. ACCESSORIES	7
APPENDIX A: Control output	8
B: Calibration curve	9
C: Lay-out plan	10

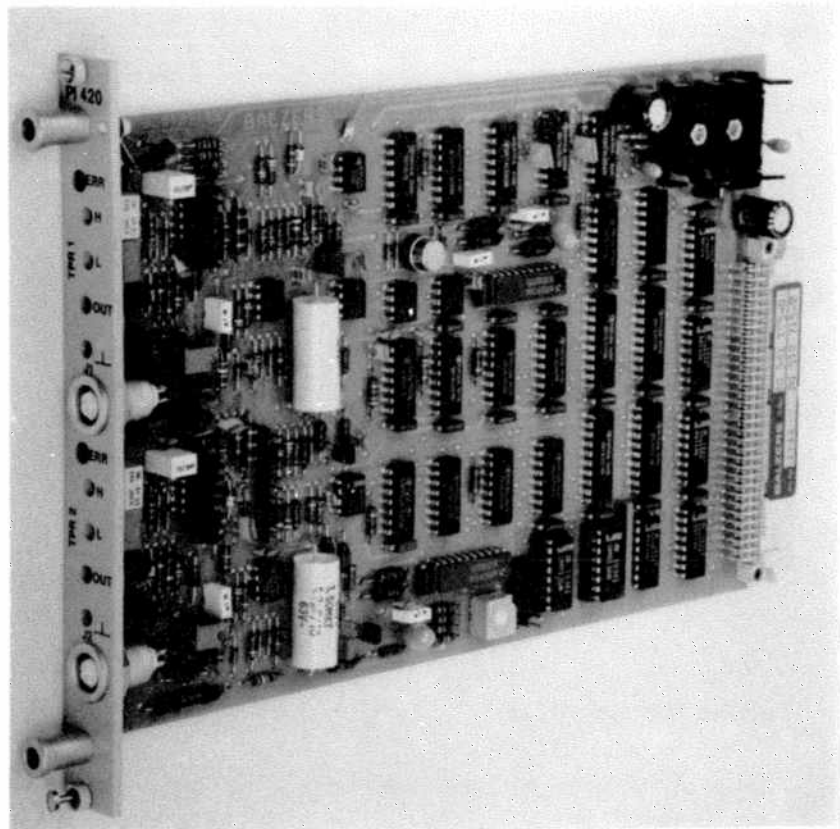

### 1. INTRODUCTION

The PI 420 Pirani vacuum module is used for total pressure measurement in the range from  $10e3$  to  $10e-3$  mbar ( $1000 - 10^{-3}$  mbar).

Two TPR 010 gauge heads can be connected to one PI 420 board.

## 2. FEATURES

- 2 channels
- 12 (11) bit resolution
- 2 control bits/channels
- Analog control output
- Control LED

## 3. SPECIFICATION

### General

Designation	PI 420
Parts list/Order Nr.	BG 512 715 -T
Diagram Nr.	BG 541 175 -S
Drawing Nr.	BG 512 716 -Z
Board format	DIN 4-HE* 220 mm (SC 420 format)
Space requirements	4TE (1 slot)

Power consumption	+5V ±5% 560 mA
	+24V ±5% 180 mA
	-24V ±5% 70 mA

Bus interface	as for BS 420
Bus load	AC 1.3 (1 = 9.35 pF)
	AC 0.5 (1 = 0.103 mA)

### Pirani data

Measuring range (N2)	1.0e-3 .. 1.0e+3 mbar
Transient time (10 – 90%)	50 ms
Error of measurement, absolute	±20%
Reproducibility	±3% (10 – 90% of the measurement range)
Gas type dependency	(see calibration curve, Appendix B)
Digital data	11 bit binary
Control bits	out-of-range (measuring range) error (gauge head or cable defective)

Connectors J1, J2	Fischer 4p
Control connector OUT	2 mm socket
Control output	0 – 10 V, Ri approx. 100 Ohm (see Appendix A for values)

### **Abgleich des PIRANI-Moduls PI 420 in BPU/VAC 420-Steuerung**

Die Software dieser Steuerungen ist so ausgelegt,  
dass die Druckbereiche  $<10^{-3}$  mbar und  $\geq$ ATM als "Out range"  
angezeigt werden.

Entgegen der Betriebsanweisung (Abschnitt B.)  
sind die Potentiometer H und L so einzustellen,  
dass die LED gerade **noch** leuchten:

- H - Röhre TPR an Atmosphärendruck
- L - Röhre TPR auf  $<10^{-3}$  mbar evakuiert

Dieser Abgleich kann generell bei allen PI 420 vorgenommen werden.

### **Adjusting the PI 420 Pirani module in BPU/VAC 420 controls**

The software in this control is designed so that the pressure  
ranges  $<10^{-3}$  mbar and  $\geq$  atm are indicated as "out range".

Contrary to the statement in the operating instructions  
(Section B), potentiometers H and L must be adjustet just **above**  
the point where their corresponding LED's go out.

- H - TPR gauge head at atmospheric pressure
- L - TPR gauge head at  $<10^{-3}$  mbar

This adjustment can be made on all PI 420's.

### **Ajustage du module Pirani PI 420 dans la commande BPU/VAC 420**

Le logiciel de ces commandes est conçu de façon telle, que les  
domaines de pression  $<10^{-3}$  mbar et  $\geq$ ATM sont affichés comme "Out  
Range".

Contrairement aux indications de l'instruction de service  
(paragraphe B), les potentiomètres doivent être réglés de manière  
à ce les diodes soient **tout juste** allumées:

- Jauge H TPR à la pression atmosphérique
- Jauge L TPR évacuée à  $<10^{-3}$  mbar

Cet ajustage peut être fait sur tous les modules PI 420.



#### 4. DESCRIPTION

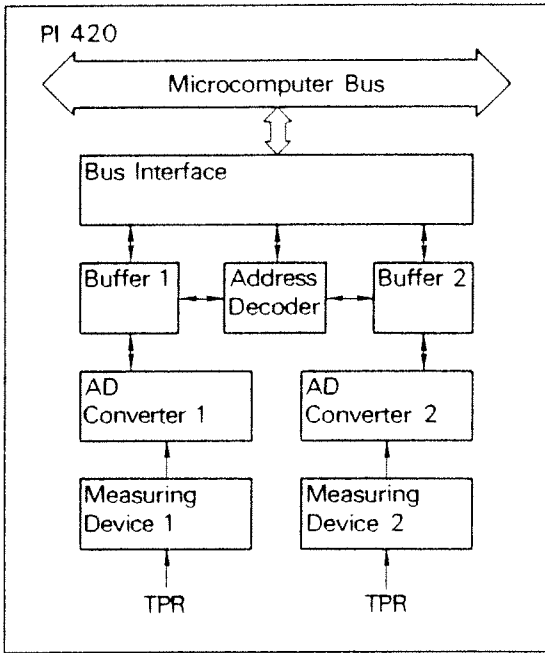

The board contains balanced BRIDGES, LOGARITHMIC AMPLIFIERS, A/D CONVERTERS and a BUS INTERFACE to the bus system.

The analog measured values are digitized in a 12 bit A/D converter to binary values. They can be read at any time via the BS 420 bus.

#### 5. CONFIGURATION

The positions of the address jumpers and the code switches can be taken from the lay-out plan (Appendix A).

Octal

1	7	4	0	X	X
---	---	---	---	---	---

Address Bit

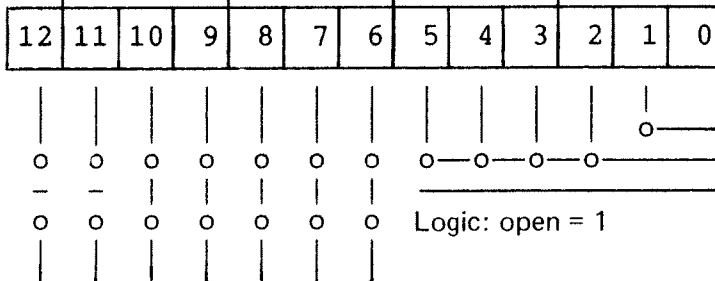

Channel 1/2  
 Code switch  
 Wrap connection  
 Logic: open = 1

- The bus address is set at the factory to %0 1740xx. This can be changed over the wrap connections if necessary
- Using the hexadecimal coding switch, the address is set in continuous sequence from 0 174000 to 0 174076 i.e the first board on 0, the second 1 etc. In this way 16 boards and thus 32 gauge heads can be addressed without changing the base address.

- Each board has two addresses. Address 1 = Measured value 1, Address 1+2 = measured value 2 (such as 174000 and 174002 octal).
- There are thus two data words (read only) per board available to the computer

## 6. INSTALLATION

- The unit must be turned off before any manipulation is undertaken on the module or its connectors. Please read Section 6.3 "Installing the modules" in the SC 420 operating instructions.

## 7. PROGRAMMING

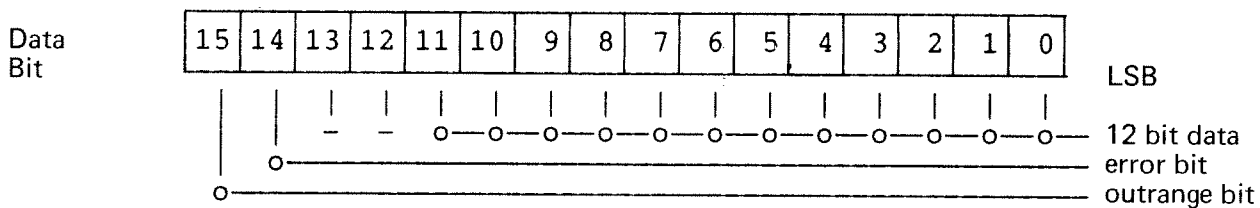

Bit 15 = Pirani data out-of-range

Bit 14 = Error (Pirani gauge head or connection)

Bit 1 – 11 = Measured value

Bits 0, 12, 13 are not used (Bit 0 is a toggle bit for the counting A/D converter)

This is a read-only board and requires no data. The 16 bit word contains the status and the measured value for one gauge head.

**Example** in MicroPowerPascal (DEC)

```
[SYSTEM(MICROPOWER)] PROGRAM read_pi_value;
(* -----
C
C COPYRIGHT (c) 1985 BY BALZERS AG,
C FL-9496 BALZERS, LIECHTENSTEIN
C ALL RIGHTS RESERVED.
C
C THIS SOFTWARE IS FURNISHED UNDER A LICENSE AND MAY BE USED AND COPIED
C ONLY IN ACCORDANCE WITH THE TERMS OF SUCH LICENSE AND WITH THE
C INCLUSION OF THE ABOVE COPYRIGHT NOTICE. THIS SOFTWARE OR ANY OTHER
C COPIES THEREOF MAY NOT BE PROVIDED OR OTHERWISE MADE AVAILABLE TO ANY
C OTHER PERSON. NO TITLE TO AND OWNERSHIP OF THE SOFTWARE IS HEREBY
C TRANSFERRED.
C
C File Name : EXAMPL.PAS
C Creation : 04-SEP-85
C Author : /ESS
C Version : V01.00
C
C
C FUNCTIONAL DESCRIPTION:
C This program reads one dataword from the Pirani board, tests for error and displays each pressure
C value on the screen.
C
C
C MODIFIED:
C
*)
```

```

CONST
  pirani_adresse = %0'174000';    (* Pirani Hardware Address *)

TYPE
  TPR_010 = [READONLY,VOLATILE] PACKED RECORD
    data:    [POS(1),BIT(11)] 0..2047;
    error:   [POS(14)] BOOLEAN;
    outrange: [POS(15)] BOOLEAN;
  END;

  tab = PACKED ARRAY[0..255] OF REAL;

CONST tpr_tab = tab (
  1.0E-03,1.1E-03,1.3E-03,1.4E-03,1.5E-03,1.6E-03,1.8E-03,2.0E-03,
  2.2E-03,2.4E-03,2.7E-03,3.0E-03,3.2E-03,3.4E-03,3.7E-03,4.0E-03,
  4.2E-03,4.5E-03,4.7E-03,5.0E-03,5.3E-03,5.5E-03,5.7E-03,6.0E-03,
  6.2E-03,6.5E-03,6.7E-03,7.0E-03,7.4E-03,7.7E-03,8.0E-03,8.2E-03,
  8.5E-03,8.7E-03,9.0E-03,9.2E-03,9.5E-03,9.8E-03,1.0E-02,1.0E-02,
  1.1E-02,1.1E-02,1.2E-02,1.2E-02,1.3E-02,1.3E-02,1.4E-02,1.4E-02,
  1.5E-02,1.5E-02,1.6E-02,1.7E-02,1.8E-02,2.0E-02,2.1E-02,2.2E-02,
  2.3E-02,2.4E-02,2.5E-02,2.6E-02,2.8E-02,3.0E-02,3.2E-02,3.4E-02,
  3.6E-02,3.8E-02,4.0E-02,4.2E-02,4.5E-02,4.8E-02,5.0E-02,5.2E-02,
  5.4E-02,5.6E-02,5.8E-02,6.0E-02,6.2E-02,6.4E-02,6.6E-02,6.8E-02,
  7.0E-02,7.2E-02,7.4E-02,7.7E-02,8.0E-02,8.2E-02,8.4E-02,8.7E-02,
  9.0E-02,9.2E-02,9.4E-02,9.7E-02,1.0E-01,1.0E-01,1.1E-01,1.1E-01,
  1.2E-01,1.2E-01,1.3E-01,1.3E-01,1.4E-01,1.5E-01,1.6E-01,1.7E-01,
  1.8E-01,1.9E-01,2.0E-01,2.1E-01,2.2E-01,2.3E-01,2.4E-01,2.5E-01,
  2.6E-01,2.7E-01,2.8E-01,3.0E-01,3.2E-01,3.4E-01,3.6E-01,3.8E-01,
  4.0E-01,4.2E-01,4.4E-01,4.6E-01,4.8E-01,5.0E-01,5.2E-01,5.4E-01,
  5.6E-01,5.8E-01,6.0E-01,6.2E-01,6.4E-01,6.6E-01,6.8E-01,7.0E-01,
  7.2E-01,7.4E-01,7.6E-01,7.8E-01,8.0E-01,8.4E-01,8.7E-01,9.0E-01,
  9.4E-01,9.7E-01,1.0E+00,1.0E+00,1.1E+00,1.1E+00,1.2E+00,1.2E+00,
  1.3E+00,1.4E+00,1.4E+00,1.5E+00,1.6E+00,1.7E+00,1.8E+00,1.9E+00,
  2.0E+00,2.1E+00,2.2E+00,2.3E+00,2.4E+00,2.5E+00,2.6E+00,2.8E+00,
  3.0E+00,3.2E+00,3.4E+00,3.7E+00,4.0E+00,4.2E+00,4.4E+00,4.7E+00,
  5.0E+00,5.2E+00,5.4E+00,5.7E+00,6.0E+00,6.2E+00,6.4E+00,6.7E+00,
  7.0E+00,7.2E+00,7.4E+00,7.7E+00,8.0E+00,8.2E+00,8.4E+00,8.7E+00,
  9.0E+00,9.2E+00,9.4E+00,9.7E+00,1.0E+01,1.0E+01,1.1E+01,1.1E+01,
  1.2E+01,1.2E+01,1.2E+01,1.3E+01,1.3E+01,1.4E+01,1.4E+01,1.4E+01,
  1.5E+01,1.5E+01,1.5E+01,1.6E+01,1.6E+01,1.7E+01,1.7E+01,1.8E+01,
  1.8E+01,1.9E+01,2.0E+01,2.1E+01,2.2E+01,2.3E+01,2.4E+01,2.5E+01,
  2.6E+01,2.7E+01,2.8E+01,2.9E+01,3.0E+01,3.1E+01,3.2E+01,3.3E+01,
  3.4E+01,3.6E+01,3.8E+01,4.0E+01,4.2E+01,4.4E+01,4.7E+01,5.0E+01,
  5.3E+01,5.7E+01,6.0E+01,6.5E+01,7.0E+01,7.5E+01,8.0E+01,9.0E+01,
  1.0E+02,1.2E+02,1.6E+02,2.0E+02,2.5E+02,3.4E+02,5.0E+02,1.0E+03);

VAR
  pirani : [AT(pirani_adresse)] TPR_010;

BEGIN    (* PROGRAM read_pi_value *)
  (* ----- *)
  WRITE ('Pirani: ');
  IF pirani.outrange THEN
    IF pirani.error THEN WRITE ('Error')
    ELSE WRITE ('Outrange')
  ELSE WRITE (tpr_tab[pirani.data DIV 8]);  (* Use 8 bits *)
END.    (* PROGRAM read_pi_value *)

```

## 8. MAINTENANCE

When gauge heads have been replaced, or when large deviations occur due to aging or contamination, the active diode network on the back panel must be adjusted from the two potentiometers using the control LED ERR.

Adjust the potentiometers to the point just below where the ERR LED lights

- Pot. H to atmospheric pressure
- Pot. L to =  $10e-5$  mbar (evacuated)

If the gauge head cables are over 50 m, the factory bridge adjustment should be recalibrated.

(Bridge voltage for high vacuum ( $< 10e-5$  mbar) 830 mV  
 atmosphere ( $10e+3$  mbar) 12.3 V)

Cable lengths up to 500 m ( $4 \times 0.34$  mm<sup>2</sup>) are thus possible.

UBr	Bridge voltage	(830 mV ... 12.3 V)
DBr	Bridge differential voltage DBR and DBr)	(0 .. 15 mV)
LED	Outrange (for Pirani Voltage) $> 10$ V or negative	

## 9. DETAILED DESCRIPTION

### 9.1 Balanced bridge circuit and curve correction

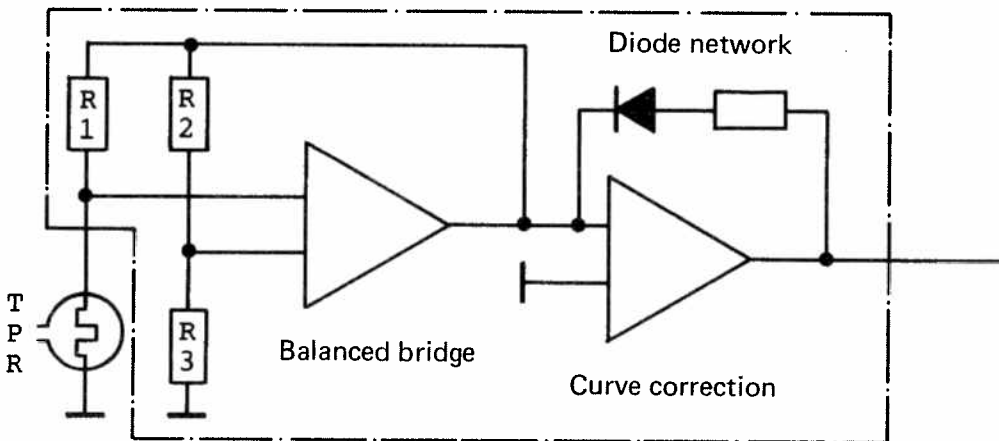

The filament in the TPR 010 gauge head used as the measuring element is one leg of a self-balancing bridge. The filament operates at 130 °C. When the pressure changes, the control amplifier automatically adjusts the bridge voltage so that the filament temperature remains the same. The bridge voltage is thus a measure of the pressure.

The following amplifier corrects the resulting signals in an active diode network and conducts it to the control output via a buffer amplifier.

## 9.2 Analog/digital converter

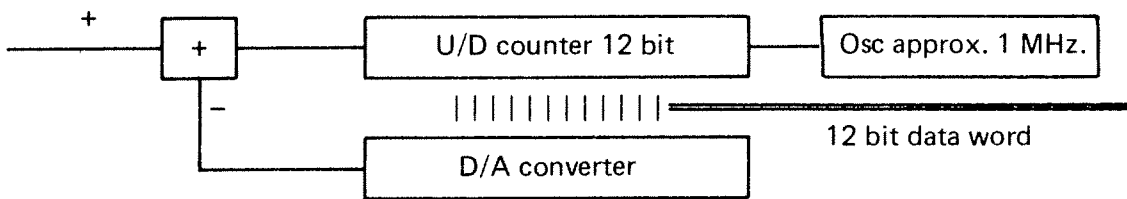

- The A/D converter consists of a 12 bit bidirectional counter, a 12 bit D/A converter and clock generator
- The input voltage ( $U_e = 0 - 10 \text{ V}$ ) is compared with the D/A converter's compensation voltage. The D/A converter used in this circuit has a current output and produces a compensation current of between 0 and 4 mA over a 2K5 resistor.
- If the voltage drop at 2K5 is lower than the input voltage, the counter increments. This increases the current i.e. the voltage drop until it equals the input voltage. When the difference is  $> 1/2 \text{ LSB}$ , the comparator switches over at every clock beat. (The last bit jumps back and forth constantly (toggle-bit)). The 12 bit counter value corresponds to the binary value of the input voltage ( $10 \text{ V} = 7777 \text{ octal}$ ).
- If the input voltage changes, the counter and thus the compensation voltage also change at a speed of approx.  $2.5 \text{ mV}/\mu\text{s}$  and at a clock frequency of 1 MHz (tracking A/D converter)
- The clock generator is stopped when the digital values are being read
- This type of A/D converter allows fast data access (necessary for the control function) and guarantees that RF interference has little effect on the accuracy of measurement.

## 10. ACCESSORIES

Please refer to the Balzers catalog "Vacuum Components"

APPENDIX A:

TABLE: Control output (0 – 10 V)  $\Leftrightarrow$  Pressure

Voltage [V]	Pressure [mbar]	Voltage [V]	Pressure [mbar]	Voltage [V]	Pressure [mbar]
0.0	$\leq e-4$	3.12	$7.0e-2$	6.92	$5.0e 0$
0.1	$1.0e-3$	3.29	$8.0e-2$	7.08	$6.0e 0$
0.22	$1.5e-3$	3.44	$9.0e-2$	7.21	$7.0e 0$
0.3	$2.0e-3$	3.60	$1.0e-1$	7.34	$8.0e 0$
0.45	$3.0e-3$	3.96	$1.5e-1$	7.51	$9.0e 0$
0.6	$4.0e-3$	4.14	$2.0e-1$	7.68	$1.0e+1 (10)$
0.75	$5.0e-3$	4.50	$3.0e-1$	8.25	$1.5e+1$
0.9	$6.0e-3$	4.72	$4.0e-1$	8.58	$2.0e+1$
1.05	$7.0e-3$	4.96	$5.0e-1$	8.99	$3.0e+1$
1.19	$8.0e-3$	5.17	$6.0e-1$	9.20	$4.0e+1$
1.35	$9.0e-3$	5.32	$7.0e-1$	9.37	$5.0e+1$
1.52	$1.0e-2$	5.50	$8.0e-1$	9.49	$6.0e+1$
1.94	$1.5e-2$	5.62	$9.0e-1$	9.56	$7.0e+1$
2.09	$2.0e-2$	5.72	$1.0e 0 (1)$	9.63	$8.0e+1$
2.38	$3.0e-2$	5.96	$1.5e 0$	9.68	$9.0e+1$
2.57	$4.0e-2$	6.26	$2.0e 0$	9.70	$1.0e+2 (100)$
2.73	$5.0e-2$	6.58	$3.0e 0$	10.0	$1.0e+3 (1000)$
2.97	$6.0e-2$	6.74	$4.0e 0$		

## APPENDIX B:

### Calibration curve for various gases

Angezeigter Druck  
(Instrument für Luft geeicht)

Indicated pressure  
(Calibrated for air)

Pression indiquée  
(Instrument étalonné pour l'air)

$p$  [mbar]

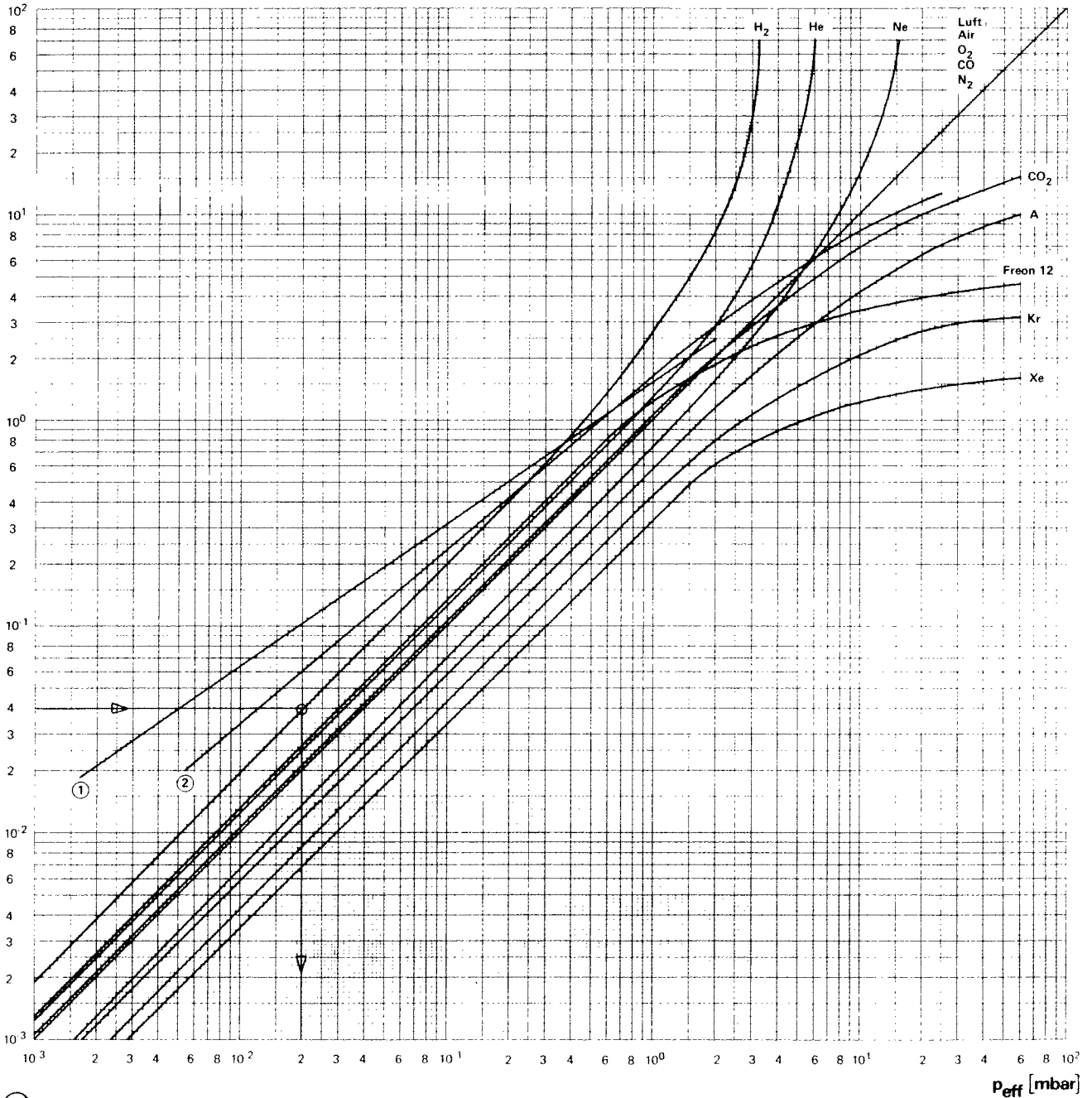

- ① H<sub>2</sub>O-Dampf, mit konstanter Brückenspannung  
Water vapor, with constant bridge supply  
Vapeur d'eau, avec alimentation constante du pont
- ② H<sub>2</sub>O-Dampf, mit konstanter Heizfadentemperatur  
Water vapor, with constant filament temperature  
Vapeur d'eau, avec température constante du filament

Eichkurve zu TPR 010/011/012, etc.  
für verschiedene Gase bei 20 °C (Mittelwerte)

Calibration curves for TPR 010/011/012 etc.  
for different gases at 20 °C (Average)

Courbes d'étalonnage pour TPR 010/011/012 etc.  
pour différents gaz à 20 °C (Valeurs moyennes)

